

CAD FILE:

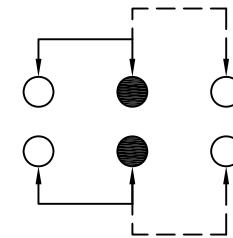

SCHMATIC (NON-SHORTING)

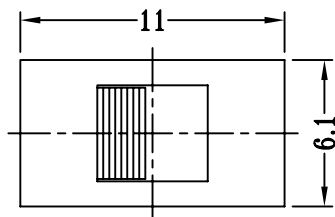
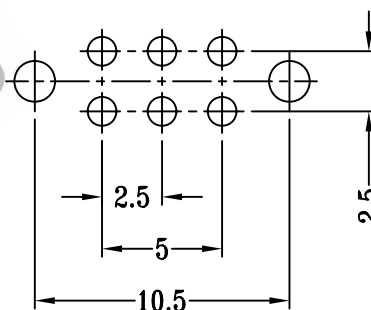
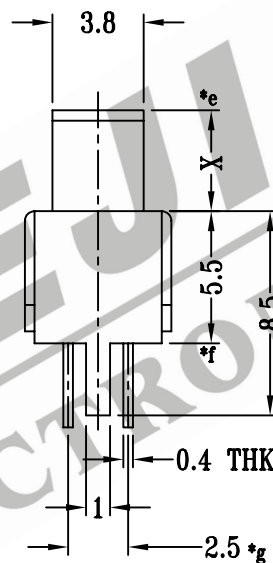
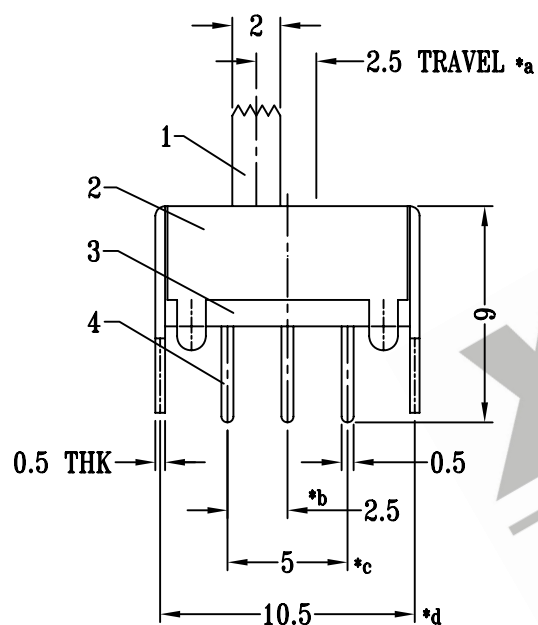

P.C.BLAYOUT

注:带"*"表示关键尺寸(7个)

8					TOLERANCE UNLESS SPECIFIED	SHENZHEN XIEJIA ELECTRONICS CO.,LTD.				
7										
6	SPRING	STEEL WIRE	2	TEMPER	WITHIN: 1.5±0.1mm	ISSUE	DATE	DESCRIPTIONS		APPD.
5	CONTACT CLIP	COPPER STRIP	2	Ag PLATED	OVER : 1.5±0.2mm					
4	TERMINAL	BRASS STRIP	6	Ag PLATED OVER Ni PLATED	TITLE : HORIZONTAL SLIDE SWITCH	UNIT : MM	DRWG NO.: XJ-DR-SS22E01-00			
3	BASE	PHENOLIC RESIN	1	ORANGE						
2	FRAME	STEEL STRIP	1	Ni PLATED	MODEL: SS-22E01	SCALE: 3:1	DWN.	ZHOUYU	2002-4-10	
1	KNOB	POM	1	BLACK			CHK'D	FANGYING	2002-4-10	
NO.	PART NAME	MATERIAL	Q'TY	FINISHING	ALL MATERIALS MUST BE COMPLIANT TO ROHS			APPD.	KANGXINAN	2002-4-10